

### VHF 700W TRANSMISSION SYSTEM FOR LONG RANGE COMMUNICATIONS

The SE900x16 transmission system has been designed for long range communication when there is no possibility to install a remote site for extended range.

Compared with high output power transmitter systems using valves, the SE900x16 system offers the following significant advantages :

- fully solid state system,
- wide band design (no amplifier or filter tuning),
- utmost stability of transmission parameters (frequency, power and modulation),
- fully protection against load mismatch, including antenna short or open circuit,
- very limited maintenance is required.

Because the SE900x16 is basically composed of 16 conventional transmitters and coupling devices, by design, the system is fully redundant and exhibits an exceptional operational availability (no service interruption despite the failure of one unit), thus allowing one installation without standby equipment.

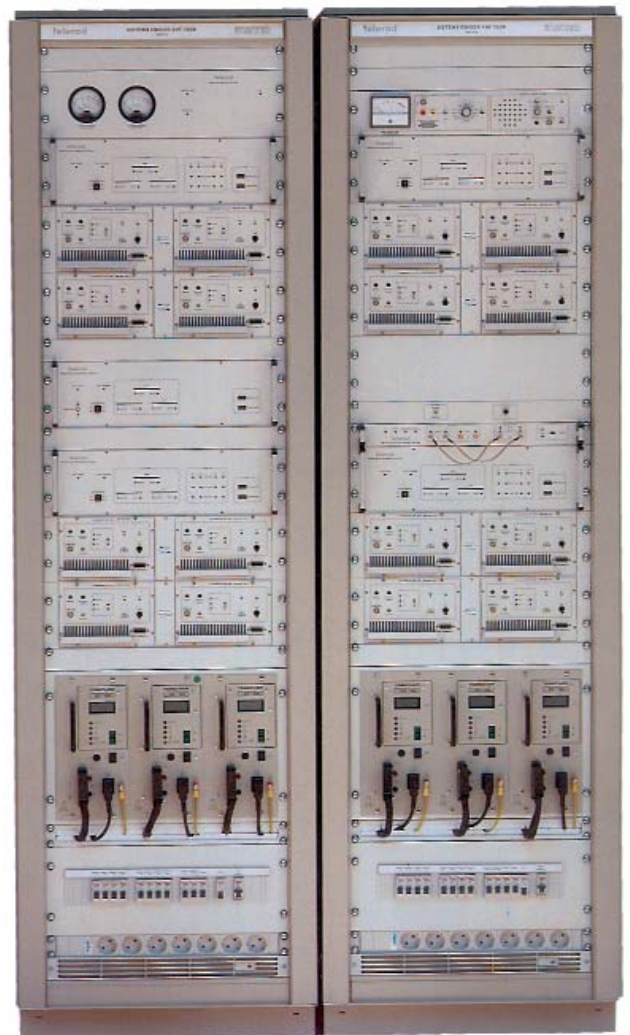

The exchange of most of the units composing the system can be achieved while the system remains in operation. All the vital functions using active elements are duplicated and monitored.

At last, the transmission system SE900x16 is equipped with wide telemonitoring possibilities implemented in order to give the user a detailed view of the operation of each unit composing the system part.

## GENERAL CHARACTERISTICS

- **RF:**
  - Frequency range: 118 to 137MHz
  - Channel spacing: 25kHz and 8.33kHz
  - Frequency stability:  $\leq 1\text{p.p.m.}$
  - Output power on 50 W:  $\geq 700\text{W}$
  - Operation with load mismatch: nominal power up to VSWR = 2:1, power reduction for VSWR > 2:1, protected operation on infinite VSWR
  - Typical variation of output power according the number of transmitters in operation:  
15 transmitters : -0.56dB, 14 transmitters : -1.16dB  
13 transmitters : -1.8dB, 12 transmitters : -2.5dB
- **Spurious and noise:**
  - Harmonics: < -83dBc
  - Wide band noise (DF > 1% F<sub>0</sub>): < -150dBc/Hz
  - Adjacent channel power:  $\leq -50\text{dBc}$
- **Modulation:**
  - AF input: 600 W balanced line
  - Maximum input level: +10dBm
  - Sensitivity for 80% mod: adjustable between -30dBm and 0dBm by 6dB steps
  - Type of modulation: A3E (voice)
  - Modulation: > 80% (typical 85%)
  - Audio distortion: < 5% (typical 1.5%)
  - Audio response (ref. 1000Hz):  
25kHz channel spacing: < 3dB from 300Hz to 3000Hz,  
8.33kHz channel spacing: < 3dB from 300Hz to 2500Hz, and >30dB at 3200Hz
  - Audio compressor: < 1dB of variation (typical 0.5dB) for 30dB of input variation
  - Modulation residual noise: > 45dB below 80% mod. (typical 55dB)
- **Power supply :**
  - Mains: 220V  $\pm 15\%$ , 50-60Hz
  - Consumption: approximately 25A when transmitting

## MECHANICAL CHARACTERISTICS

- **Presentation of the system:**  
2 interlocked 19" standard racks
- **Overall dimensions:**
  - width:  
124cm
  - depth:  
85cm
  - height:  
2.15m

SE 900x16

## DESCRIPTION

The 700W transmission system has been designed from an original concept developed by Telerad, and which has been adopted by the French Technical Services of the Civil Aviation (S.T.N.A) for more than 20 years. This concept consists in transmitting on one frequency with two inter-coupled transmitters, so that the RF output powers can sum up.

Regarding the transmitters, the coupling implies an operation:

- from the same frequency driver,
- at the same power level,
- with the same modulation signal.

Once got the coupling of two transmitters, there is no more difficulty to inter-couple two pairs of transmitters. Telerad already supplied Spain and Morocco with several 200W transmission systems made by coupling 4 conventional 50W transmitters.

In the present case, for 700W carrier, 4 transmission 200W systems are coupled, just as in a 200W unit 4 transmitters are coupled

The component used to sum up the RF output powers delivered by the transmitters is the -3 dB 1/4 hybrid coupler. This component has a structure of bi-coaxial quadripole with an electric length of 1/4.

Thanks to its properties, if any signals with determined phase and amplitude relations are introduced in two adjacent ports, the power of these signals is summed to a third port, whereas the fourth port remains isolated. If optimum phase and/or amplitude relations are not respected, a signal appears on this last port related with the imbalance level. This port is connected with a 50 ohms dummy load and has a detection device for imbalance signalling and alarm.

## SYSTEM COMPOSITION

The power supply sub-system is composed of 2 groups of three power supply units, each providing a D.C. voltage of 28V from the 220V A.C. mains. The three power supply units of each group operate in parallel to supply the energy which is required by half part of the system. With a capacity of 60A each, two power supply units would be enough to cover the consumption. The third one is installed to insure redundancy.

In addition, the 700W VHF transmission system is composed of the following equipment:

- **EM 900S8 conventional 50W VHF transmitters (16)**
- **SPY 900 frequency driver selection unit (1):**  
This unit permits all the transmitters to be supplied with the same frequency signal delivered by one of the four incorporated frequency drivers. By redundancy, two frequency drivers are operational at the same time, one being the standby of the other, with automatic change-over. The two other frequency drivers are installed as spares (manual coaxial connections on the front panel).
- **CPV 200 coupling unit for 4 transmitters (4):**  
It provides to the transmitters the P.T.T, the modulation and the frequency driving signals, and sum up the RF output powers. The couplers are incorporated in the unit, but the 50 ohms dummy loads are external. The unit includes indicators and controls for optimum coupling adjustment. It also supervises the transmitters operation and the coupling conditions.
- **CPV 700 coupling unit for 4 groups of 4 transmitters (1):**  
It is the main coupling unit. It operates exactly as the CPV 200 does. The couplers and the dummy loads are external because of its size. It supervises the operation of the groups of transmitters.

SE 900x16

## WIRING

The coaxial wiring of this system is quite specific : being a VHF system, the coaxial cable lengths must be minimised and have to be identical for a same coupling level. In spite of the numerous connections imposed by the important number of units, the connections inside the racks are easy, thanks to a systematic identification of the cables and of the units. The signals are also clearly identified on the remote control and telemonitoring connection terminals.

## VENTILATION

The racks are normally cooled down by fresh air introduced at the bottom through an opening in the dummy floor. A blower unit, located under the power supplies, makes the cooling down easier. Besides, each transmitter has its own cooling fans. Under extreme conditions, or should the ventilation of one transmitter fail, the transmitter is protected by a gradual reduction of the output power according the temperature.

## SYSTEM BLOCK DIAGRAM

This block diagram shows the architecture of the system. The transmitters are associated by groups of 4 around a same CPV 200 unit. The CPV 700 unit then associates the 4 groups.

We can notice the interface with the user's system: remote control, telemonitoring, antenna.

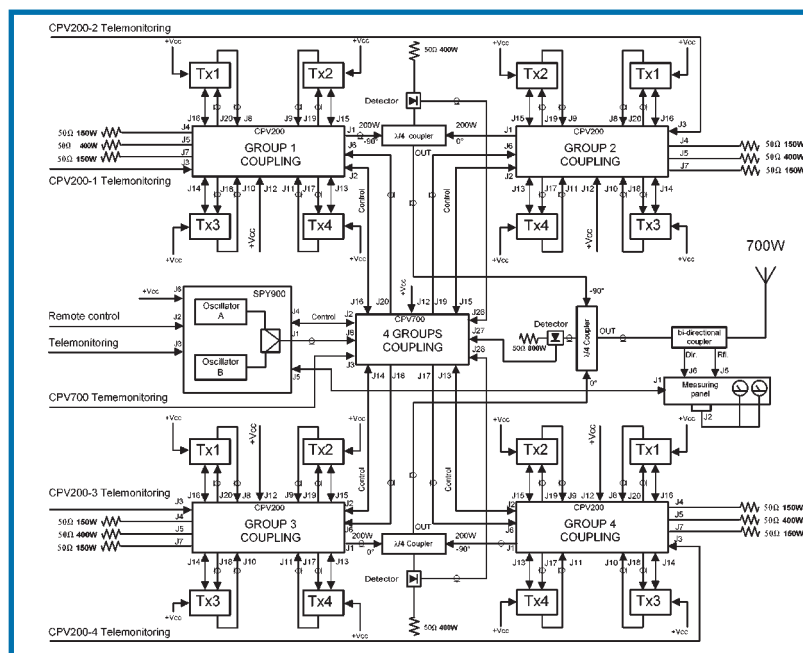

RACK B

RACK A

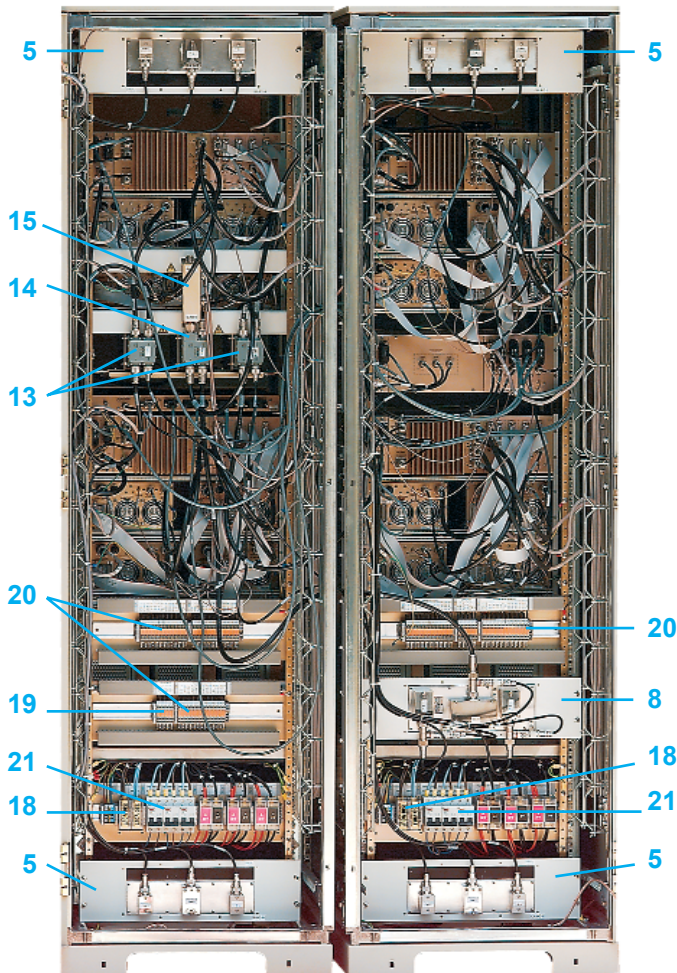

RACK A

RACK B

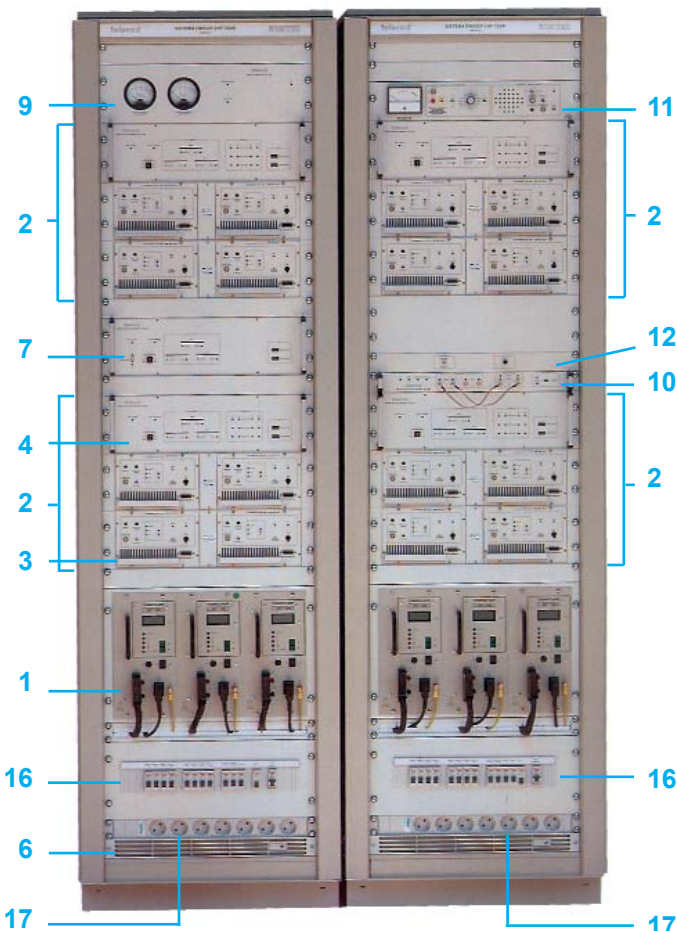

SE 900x16

## REALISATION

The system is installed in two racks called "rack A" and "rack B", each 42U high and 800mm deep. On installation these racks are interlocked in order to constitute a monolithic unit.

### Each rack includes:

- (1) three mains power supply units
- (2) two 200W groups, each including:
  - (3) four EM 900 S8 transmitters
  - (4) one 200W CPV 200 coupling unit
  - (5) one DISS26137 dummy load panel with heat sink
- (6) one blower unit located under the d.c. power supplies

### Moreover, the "rack A" also includes:

- (7) one 700W CPV 700 coupling unit
- (8) one DISS29017 dummy load panel with detectors and radiator
- (9) one PM 1000 panel for measuring the output power and the reflected power

### The "rack B" also includes:

- (10) one SPY 900 frequency driver selection unit
- (11) one PM 880 measurement panel for the transmitters
- (12) one control panel for maintenance, with P.T.T. push-button and a normal/reduced power switch
- (13) two 200W power couplers
- (14) one 700W output coupler
- (15) one BIRD measurement coupler on the antenna output

On the front panel, at the bottom of the racks, one can find a row of circuit-breakers (17) insuring an individual protection on the power supply unit of each equipment, as well as a protection of the electric plugs. A mechanical protection (which is not implemented on the picture) prevents the circuit-breakers to be accidentally actuated, while permitting a free access to the control levers.

The mains is connected on terminals (18).

Remote control and telemonitoring signals are respectively connected on the groups of terminals (19) and (20).

The outputs of the power supply units are protected by the circuit-breakers (21).

The back doors of the racks open in opposite sides, thus permitting access to the two racks at the same time.

In the "rack B", a mobile lighting system with magnetic support has been installed. It permits to light any part inside one or the other rack. Doors are equipped with document case.